



## Materials Datasheet

## Moisture Barrier Bag

### MBB

#### PRODUCT DESCRIPTION

Reel Service Limited's Moisture Barrier Bag (MBB) is manufactured from multiple layers and designed to provide packaged components ultimate protection from moisture and static damage.

The bags also have the Moisture Sensitive Caution label pre-printed.

Reel Service MBB's are available in a range of sizes to suit reels, trays & tubes.

The bags meet the requirements of:

J-STD-033,

MIL-PRF-81705 Type

EIA 541

EIA583

EIA625

#### Material Composition

Anti Static
Aluminized Polyester
Dissipative Nylon
Cast Polyethylene
Aluminium Foil
Anti Static Aluminized Polyester

#### SUPPLY FORMAT OPTIONS

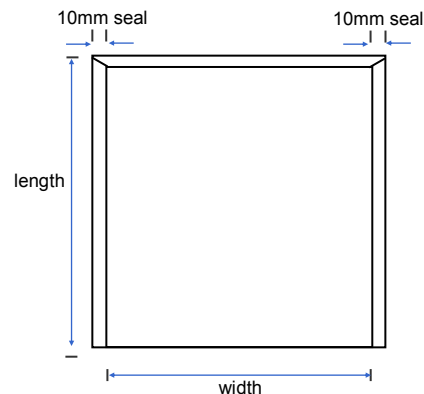

#### PHYSICAL PROPERTIES

Property	Value	Test Standard
Thickness	90 microns	
Seal Strength	>3kg/cm	GB/96-04-10
Tensile Strength	63N/15mm	DIN55531
MVTR (g/100 sq.in/24hrs)	<0.0003	DIN53122
Surface Resistivity Interior	<10e11ohms	ANSI/ESD STM11.11
Surface Resistivity Exterior	<10e11ohms	ANSI/ESD STM11.11
Static Decay	<2 secs	FTMS101 MTH 4046

Standard and custom sizes available.

#### CUSTOMER SERVICE

Our customer service and technical support teams can assist in all aspects of specifying and sourcing your entire in-house tape & reel material requirements including carrier tape, cover tape, reels & moisture protection products.

For further assistance, please contact our Customer Service Department at the email address below.

#### Disclaimer:

The information provided is accurate to the best of the company's knowledge or is obtained by sources believed by the company to be accurate and does not imply any legally binding assurance.

The Company reserves the right to introduce at any time improvement to the above product(s) without prior notice.