

7-INCH DIAMETER REELS

PRODUCT DESCRIPTION

The 7 inch Diameter reels manufactured by Advanced Integrated Materials provide the latest addition to our full range of take up reels, carrier and cover tape supplies.

These polystyrene reels are designed to maximum strength to ensure complete component protection and lead integrity. Our design provides windows on one side for easy visual reference whilst providing adequate labelling space.

We offer full ESD protection with our static dissipative reels available in a range of tape widths from 8mm – 16mm.

Our 7 inch reels are supplied as complete reels. Our one-piece moulding process eliminates adhesion problems inherent with bonded reels designs.

BASE MATERIAL

Static Dissipative: Polystyrene with Integrated Antistatic Additive

SURFACE RESISTIVITY

Static Dissipative Reels: Static Dissipative with surface resistivity of Less than 1×10^{12} ohms per square.



COLOUR AND WINDOWS

Static dissipative 7-inch reels are available in white and offer a window design providing easy visual reference whilst maintaining ample labelling space and reel strength.

RECYCLABLE SPACE SAVING DESIGN

Our polystyrene base material allows users an environmentally friendly, recyclable reel.



REEL DIAMETER

The one-piece injection moulded reels manufactured by AIM are available with a 7-inch (178mm) reel diameter. Contact our customer service departments for our complete range of 7-inch 13-inch and 15-inch reel sizes.

HUB WIDTH AND ASSEMBLY

The hub diameter is 2.36 inches (60 mm) available in widths of 8mm, 12mm and 16mm, making these reels ideal for maximum utilization of reel space for small sized components or small volume requirements.

SHELF LIFE AND STORAGE CONDITIONS

With a shelf life of two years, recommended storage conditions for 7 inch reels are: storage indoors away from direct sunlight within a temperature range of 18 C to 35 C (64 F to 95 F) and relative humidity levels of 35% – 65%.

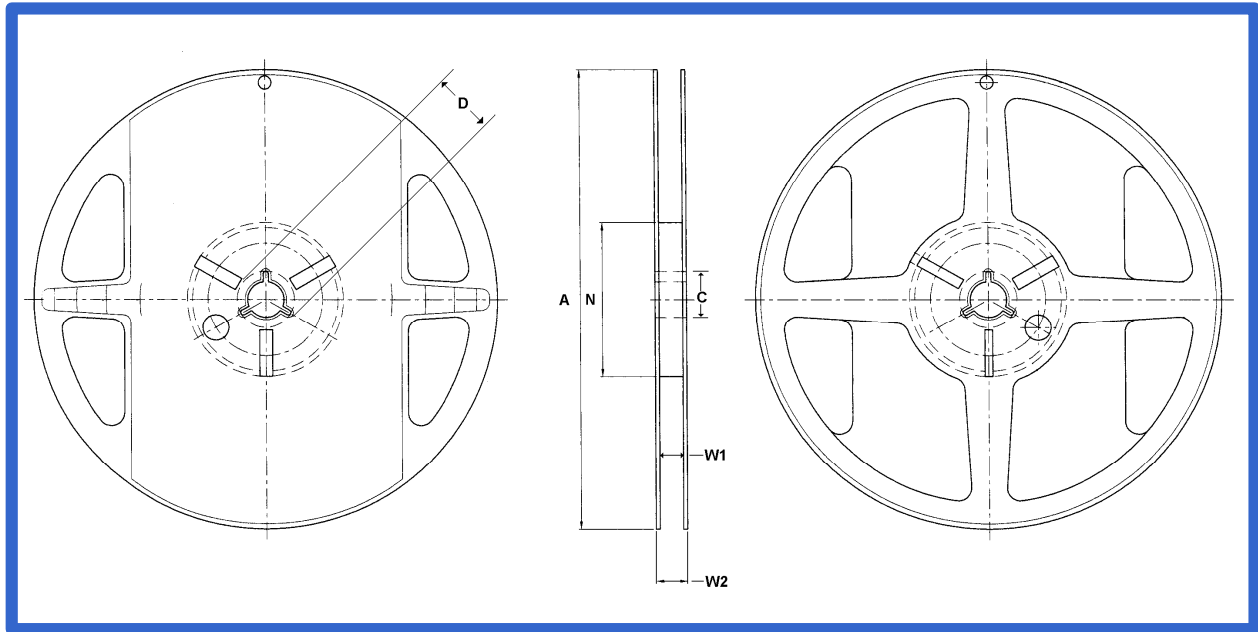

DIMENSIONS FOR STATIC DISSIPATIVE 7-INCH MOULDED REELS						
Tape Width	A Diameter	C	D (min)	N Hub	W1	W2 (max)
8	178 +/- 1.0	13.5 +/-0.5	20.2	60 +0.1 -0.0	9 +/- 0.5	11.5
12	178 +/- 1.0	13.5 +/-0.5	20.2	60 +0.1 -0.0	13 +/- 0.5	15.5
16	178 +/-1.0	13.5 +/-0.5	20.2	60 +0.1 -0.0	17 +/- 0.5	19.5
24	178 +/-1.0	13.5 +/-0.5	20.2	60 +0.1 -0.0	25 +/- 0.5	27.5
ALL OTHER DIMENSIONS AND TOLERANCES ARE FULLY COMPLIANT WITH EIA 481-C						

QUANTITY PER BOX	
Hub Width	Reels Per Box
8mm	200
12mm	120
16mm	100

The above information is accurate to the best of the company's knowledge or is obtained by sources believed by the company to be accurate and does not imply any legally binding assurance. The Company reserves the right to introduce at any time improvement to the above product without prior notice.

**7 INCH REEL PART NUMBERING REFERENCE GUIDE
ALL REELS ARE PROVIDED AS ONE PIECE COMPLETE REELS**

Part No.	Hub Width mm	Hub Diameter Inches	Flange Diameter Inches	Colour
White Static Dissipative				
RCT8MM7INCH	8	2.36 (60mm)	7 (178mm)	White
RCT12MM7INCH	12	2.36 (60mm)	7 (178mm)	White
RCT16MM7INCH	16	2.36 (60mm)	7 (178mm)	White

**Note: 24mm wide may be available on special request.
Please contact customer service for full details.**

Customer Service

Our customer service and technical support teams can assist in all aspects of specifying and sourcing your entire in-house taping requirements. Our extensive open tooling database is utilised to search for available exact fit carrier tapes.

Advanced Integrated Materials design carrier tapes for all standard and non-standardised components and can assist in cover tape and KLIK REEL recommendations. Materials required for in-house tape & reel and finished goods operations are also supplied.

Please contact our customer service department at the address below.

Warranty Statement

All products come with a one year limited warranty.

Other Products and Services Available

In addition to our reels, we offer a complete range of all materials necessary for tape and reel operations including: cover tape, carrier tapes, humidity indicator cards, moisture barrier bags, desiccant and other sundry semiconductor finishing materials.

Also available from our company is a full subcontract Tape & Reel packaging and Device Programming service.

Please contact our customer service team for further information on our complete range of Tape & Reel products and services.



Enquiries:

- Tape & Reel - Carol Grant cgrant@reelserviceltd.com
- Device Programming – Carol Grant cgrant@reelserviceltd.com
- Materials Supply – Shirley Kinnear skinnear@reelserviceltd.com

Scotland

Reel Service Ltd
55 Nasmyth Road
Southfield Industrial Estate
Glenrothes
Fife KY6 2SD
Scotland
Tell: +44 (0) 1592 773208
Fax: +44 (0) 1592 774696
www.reelservice.com

The above information is accurate to the best of the company's knowledge or is obtained by sources believed by the company to be accurate and does not imply any legally binding assurance. The Company reserves the right to introduce at any time improvement to the above product without prior notice.